

PRC6000 Digital Baseband Processor for UMTS Femtocells

Percello

Ingenuity inside femtocell

Benefits:

- Low cost digital baseband processor
- Highly integrated device
- Suitable solution for mass market
- 3GPP Rel-8 HNB compliant
- Support all 34.108 RABs

Key Features:

- 8 simultaneous users
 - 8 CS/PS calls in parallel to 8 HSPA+ data services
 - For example: 8 voice calls in parallel to HSPA+ sessions
- Support any UMTS terminal
 - DCH 384 Kbps
 - 21.6 Mbps HSDPA for UE Cat. 1 to 14
 - 5.76 Mbps HSUPA for UE Cat. 1 to 6
- MAC-(e)HS/MAC-E Accelerators
- Cell coverage - 500m
- High speed MIPS24Kc Processor
 - I Cache & D Cache
 - I & D scratchpad memories
- External Memory I/F
 - DDR2
 - FLASH/SRAM
 - FLASH-less boot
- Network Interface
 - Ethernet MAC 10/100
 - Reverse MII
 - Reduced MII
- UMTS f8/f9 Security Accelerators
- Backhaul Security Accelerators
 - USIM I/F
 - DES/3xDES
 - AES
 - RSA
 - SHA-1/SHA-2
- Timing Unit
 - Embedded IEEE 1588/NTP
 - External cell sync
- Generic digital RF I/F
- Self configuration



PRC6000 digital baseband processor enables low cost, secured and powerful UMTS femtocells

PRC6000 is the first chip of Percello's Aquilo chips family, aimed for the UMTS femtocells market. PRC6000 serves both as the central processor in a standalone femtocell and as a sub-system element for RGW system. PRC6000 uses an Ethernet connection to handle the backhaul traffic in case of standalone femtocell as well as in the RGW case.

PRC6000 contains 2 major sub-systems:

- ▶ FLE (femtocell layer1 engine) which performs all the WCDMA layer 1 Uu interconnection between the femtocell and the connected UMTS terminals.
- ▶ A powerful CPU which executes the entire upper layers UMTS stack up to the Iuh I/F (MAC, RLC, PDCP, RRC etc) and handles as well all the backhaul traffic using IP protocols.

The FLE supports HSPA+ L1 functions. These functions are controlled by the upper layers through the Iub I/F (named as FAPI by femtoforum).

Aquilo architecture combines programmable multi processing cores surrounded by powerful dedicated HW accelerators. By using Aquilo SoC architecture, Percello brings to the customer a low cost, small footprint, low power and high performance digital baseband for the enterprise and outdoor UMTS femtocells market.

Aquilo architecture was specifically designed to off load the CPU from intensive high MIPS consuming tasks, thus enabling enhanced system performance.

PRC6000 Digital Baseband Processor for UMTS Femtocells

- Dedicated baseband processor for UMTS femtocells
 - 3GPP Rel-8 HNB compliant
 - Simultaneously support Rel-99, Rel-5, Rel-6 and Rel-7 handsets
- Fully integrated femtocell digital baseband solution
 - L1 Modem
 - CPU & Peripherals
 - HW accelerators for security, backhauling, etc
- Embedded TPM capabilities
 - Secured boot
 - OTP Keys
 - Enable Secured CPE with no additional HW on board

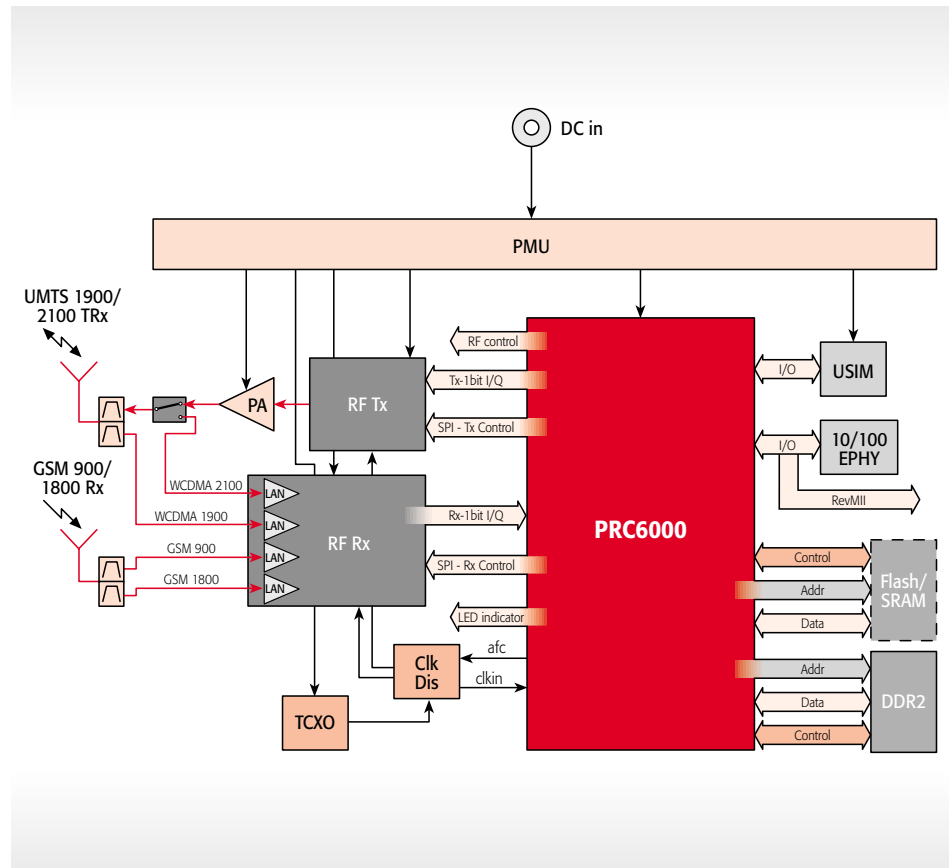

PRC6000 digital baseband processor enables low cost, secured and powerful UMTS femtocells

The PRC6000 chip contains all the elements to be the central processor in a standalone femtocell. In this mode of operation, PRC6000 is connected to external RF IC, external memories and Ethernet PHY. In a GW, which has a central CPU that handles the backhaul traffic, inter processors communication is via reversed MII.

FLE (femtocell layer1 engine) FW/SW parts are supplied by Percello and support all L1, MAC-(e)HS/MAC-E functionality up to the lub I/f (named as FAPI by femtoforum). Percello FW/SW support HSPA+ functionality and is backward compatible to support any into market UMTS Rel-99/Rel-5/Rel-6 devices.

In addition, Percello supplies BSP SW, with a set of APIs for any on die HW device. These APIs are used by the upper layers SW to manage a given device, thus concealing the HW details from the programmer.

► About Percello

Percello, a fabless semiconductor company, was founded in 2007 to provide digital baseband solutions to the challenges of the 3G/HSDPA/HSUPA/HSPA+/LTE femtocells market: cost, power, level of integration, development time and flexibility.

Percello has vast knowledge in silicon design, software and 3G/HSDPA/HSUPA/HSPA+/LTE communication systems. The company has proven capability to deliver complicated SoC from standard to mass production.

Percello
Ingenuity inside femtocell

Percello Ltd.

Headquarter and R&D

14 Hatidhar St., P.O. Box 4141, Ra'anana 43650, Israel

Phone: +972-9-7751003, Fax: +972-9-7407560

E-mail: info@percello.com